

|||| HENNIG®

PROTECT YOUR SUCCESS

# TRUMPF CONVEYOR | 3 METER TABLE

HENNIG PART #102315 TRUMPF PART #383802

MANUAL / INSTRUCTIONS / PARTS LIST

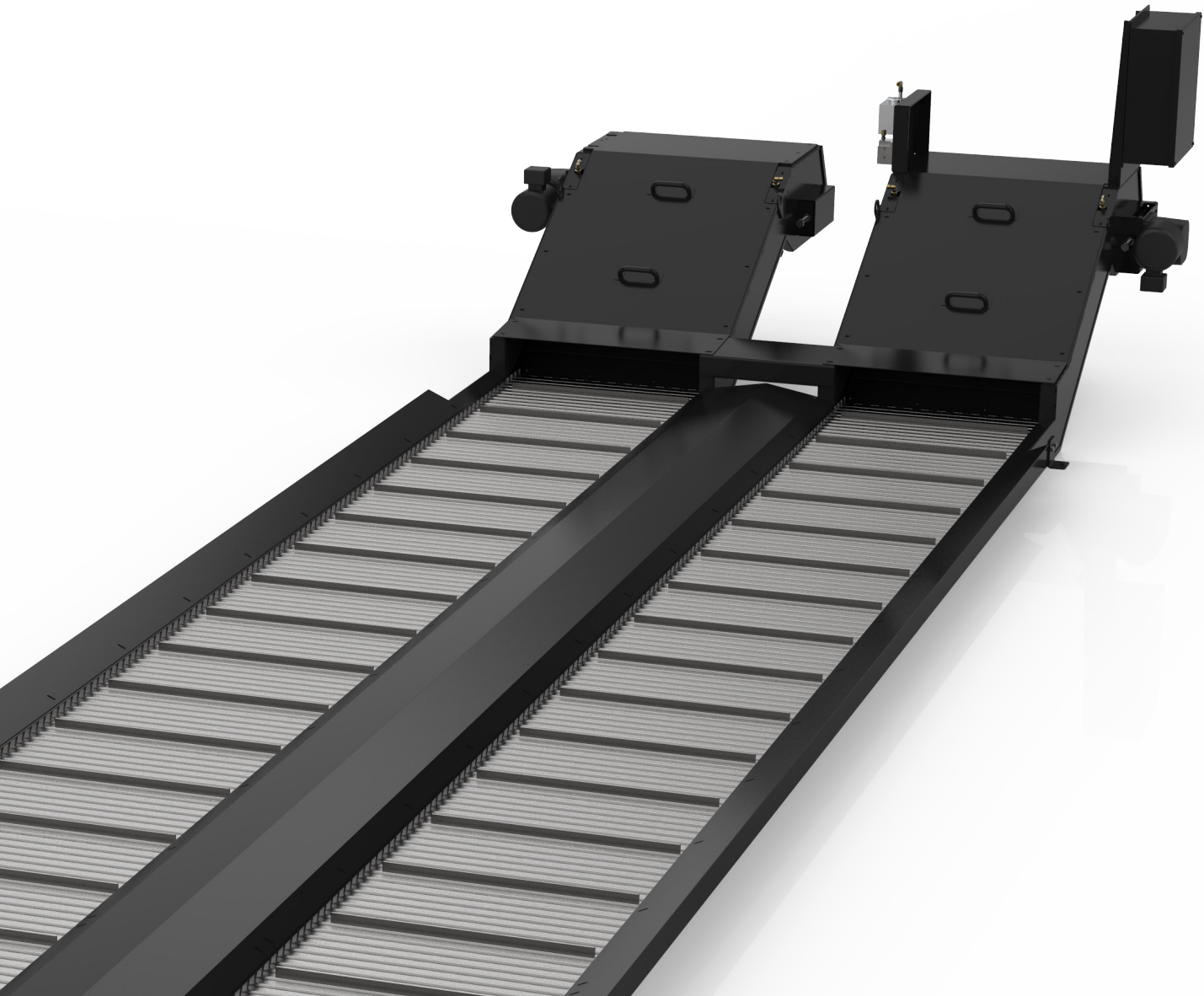

# TRUMPF DUAL CONVEYOR SYSTEM (3 METER TABLE)

<b>Hennig #</b>	102315
<b>Trumpf #</b>	383802
<b>Type</b>	Dimpled hinge
<b>Motor</b>	1/4 hp
<b>Reducer</b>	240:1
<b>Conveyor chain</b>	2060H

<b>Speed</b>	2.2 m/min
<b>Capacity</b>	671 in <sup>3</sup> /min
<b>Safety apparatus</b>	Current sensor
<b>Chips</b>	Laser dust
<b>Voltage</b>	440V / 3PH / 60Hz.
<b>Weight</b>	~ 1300 lbs



## TABLE OF CONTENTS

1. Safety Practices
2. Transport / Handling
3. Installation & Start-Up
4. Preventative Maintenance
5. Hinge Belt Removal
6. Hinge Belt Installation
7. Spare Parts

## INTENDED USE

The purpose of your system is to efficiently transport metal chips from the machine tool to a bin for recycling. The system is engineered to handle only certain types of chips. Changes to either may impact machine operation. The system must be running whenever there is a possibility of chips falling into the in-feed. **Starting the system after a large amount of chips has accumulated could result in damage to the system.** Always use a bin to catch chips when running the system. Daily and preventative maintenance (PM) are necessary to avoid unintended down-time.

**Your new Hennig system undergoes 100% end-of-line test and inspection to verify proper function, prior to packing and shipment.**

## CONTACT US

For questions regarding your system, or assistance in new applications, contact a customer service representative: 815-636-9900 or [info@hennig-inc.com](mailto:info@hennig-inc.com).

# 1. SAFETY PRACTICES

## OBSERVE THE FOLLOWING

- ① Follow the warnings and instructions of this manual, along your own safety system.  
This includes using your lock-out tag-out (LOTO) system for electrical work.



- ② Provide the proper level of training to operators and maintenance personnel.
- ③ Do not disable safety devices on your system.
- ④ Keep away from moving parts and pinch points of the system while it is operating.
- ⑤ Electrical work should only be done by authorized personnel, according to your training and safety system.
- ⑥ Keep guards/covers in place, except for maintenance.
- ⑦ Disconnect power before performing maintenance.
- ⑧ Starting the system after a large amount of chips has accumulated could result in damage to the system.

---

## RECOMMENDED PPE

- ① Eye Protection



- ② Gloves (especially when handling coolant, cutting oils, and metallic chips)



## 2. TRANSPORT / HANDLING

### 2.1 REMOVING FROM THE PALLET

The Hennig systems are shipped on separate pallets. The systems can be moved on/off their pallet with an overhead lifting apparatus (crane) or a forklift using straps. Only use the lifting eyes (shown below) for picking up the system using straps or chains. Keep the system horizontal while moving.

**Make sure your forklift/straps/chains meet the weight specifications for the system being lifted or moved (each conveyor weights ~1300 lbs).**

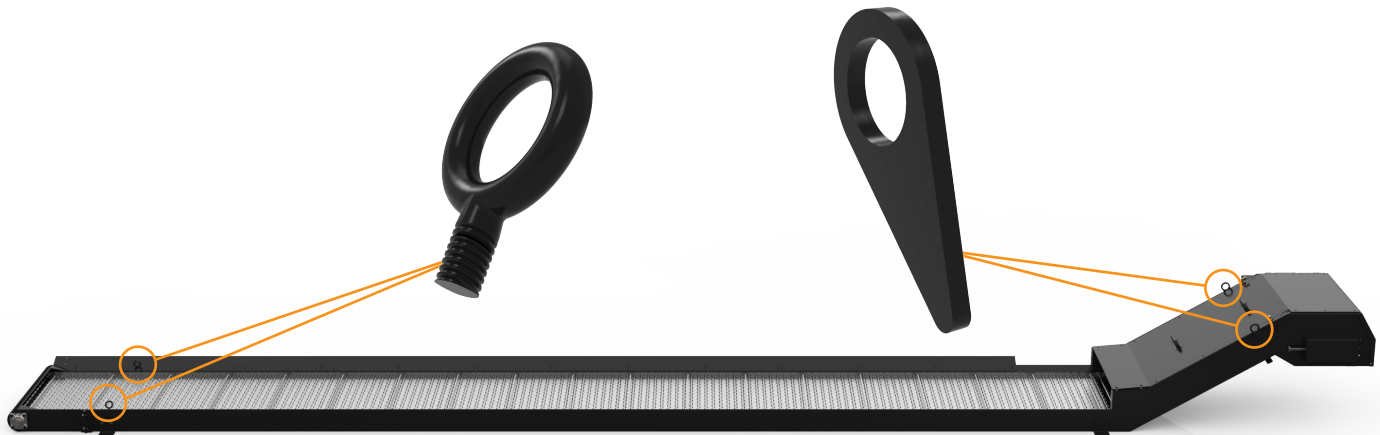

Fig. 2

### 2.2 TRANSPORTING (NEW)

The safest method to move the system is by crane or forklift using the lifting point shown above. Each system must be moved individually to avoid damage to the conveyor components.

### 2.3 TRANSPORTING (AFTER OPERATION)

- ① Unbolt from the floor.
- ② Pull system out from under the machine.
- ③ Remove all chips from the system.
- ④ Remove the chutes.

**Follow directions above (2.2 Transporting) when moving the system.**

### 2.4 STORAGE

In the event your system needs to be stored or out of service for more than 90 days, take the following steps:

- ① Remove all chips from the system.
- ② Using a shop towel or rag, wipe exposed sheet metal surfaces with a rust preventative.

**Outdoor storage not recommended.**

## 3. INSTALLATION & START-UP

### 3.1 INSPECT YOUR SYSTEM

Check the system for any damage that could have occurred during shipping. If damage is found, contact Hennig at 815-636-9900.

---

### 3.2 REMOVE PACKAGING AND DEBRIS

Remove all objects such as shipping papers, crating, etc., that may be present in the system.

---

### 3.3 ALIGN THE TWO SYSTEMS

If not already removed from the shipping pallets, do so now and place the conveyors near the open part of the machine bed.



Fig. 3a

### 3.4 INSTALL SPACER

- ① Install spacer on one conveyor.
- ② Position the second conveyor so the spacer lines up with the mounting holes, then bolt the spacer to it.

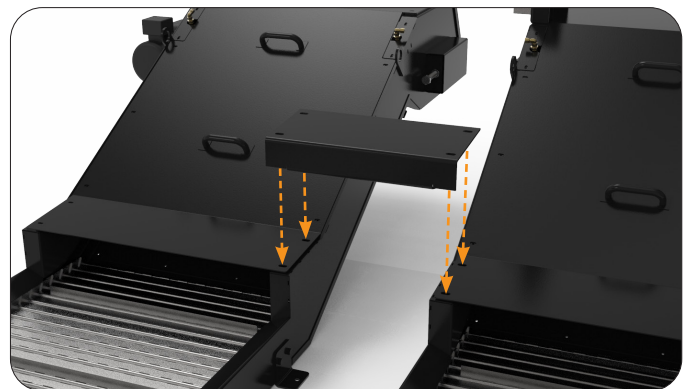

Fig. 3b

## 3. INSTALLATION & START-UP

### 3.5 INSTALL CHUTES

Use the supplied bolts and attach the chutes to the conveyors in the order shown below.

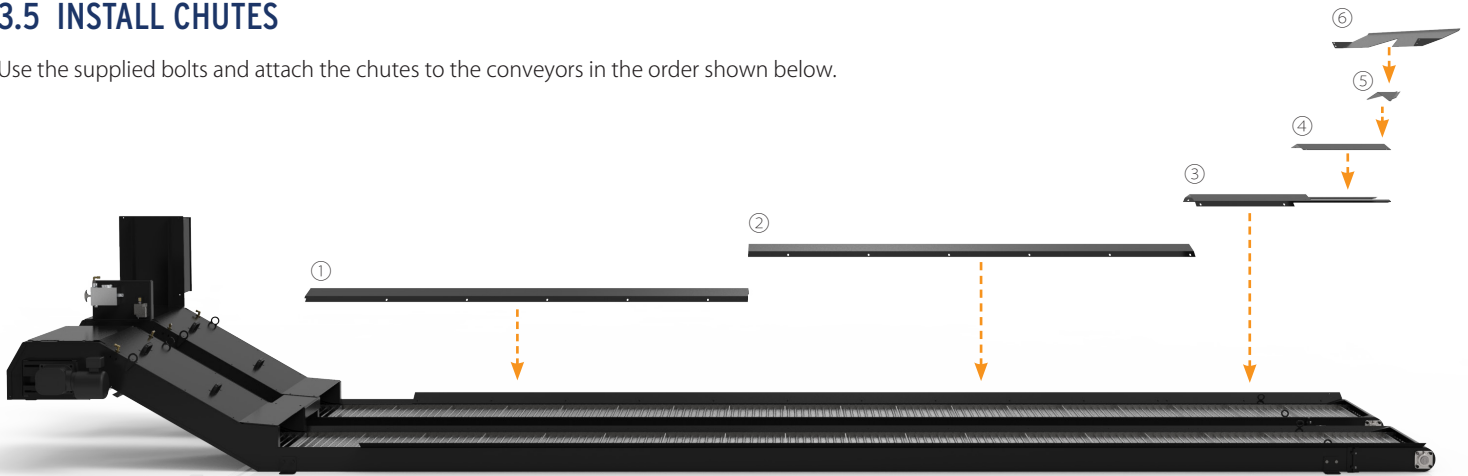

Fig. 3c

### 3.6 MOVE CONVEYOR SYSTEM INTO PLACE

- ① Position the system so that it's centered under the machine table and in line with the existing conveyor on the machine tool.
- ② Push the system under the machine bed until it meets with the existing conveyor.
- ③ Bolt the system to the floor.

### 3.7 POWER ON & RUN THE SYSTEM

Start up the system and allow it to run (without the machine in operation) for approximately an hour (without load) to ensure everything is working properly.

## 4. PREVENTATIVE MAINTENANCE

The minimum recommended interval for PM is 1000 hours after initial system startup, and every 1000 hours thereafter. Because different machines have different duty cycles, determine a maintenance interval that works best with your system. The best way to avoid unplanned down-time is to follow the list in this section for system maintenance needs.

### 4.1 GREASE THE TAKE-UP BEARINGS

The bearings are accessible by removing a cover or plate. A good, general-purpose grease is recommended. Hennig recommends Mobilgrease XHP222. Do not over-grease or bearing seal damage may result.

**Take-up bearings are found on the sides of the discharge head (one on each side of the conveyor). See below.**

Remove the cover plates on each side for take up bearing access. Take up bearings can be seen in green in the images below.

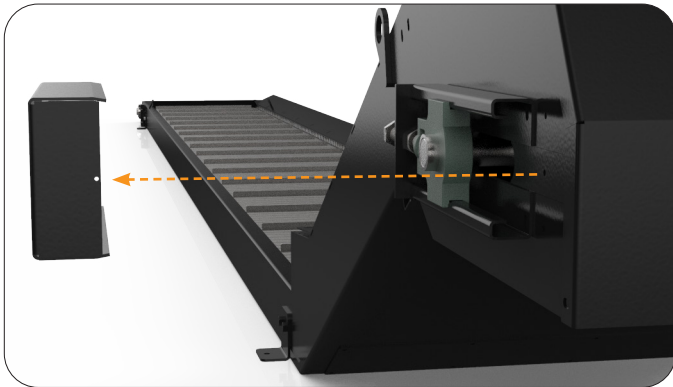

Fig. 3d

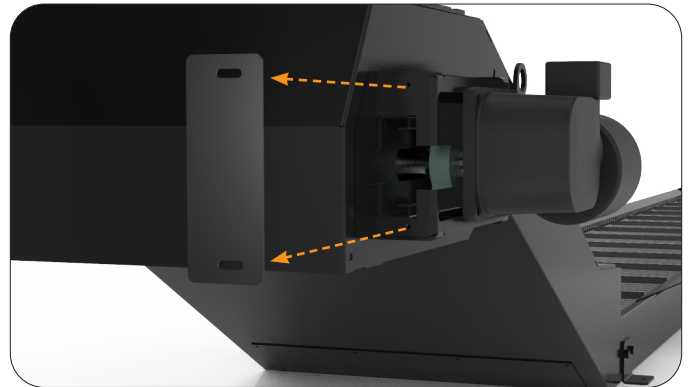

Fig. 3e

### 4.2 REFILL THE OIL LUBRICATOR

Use the sight gauge to verify oil level. Fill when necessary.

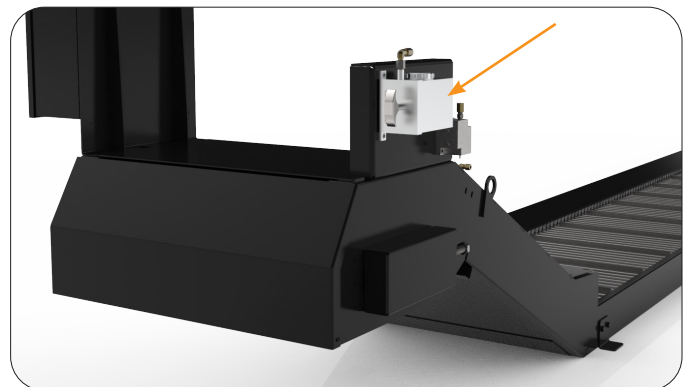

Fig. 3f

## 4. PREVENTATIVE MAINTENANCE

### 4.3 CHECK / ADJUST BELT TENSION

Torque the tension screws (one on bearing side, one on motor side) and tighten the jam nuts.

**Proper tension is 25in-lbs on both sides.**

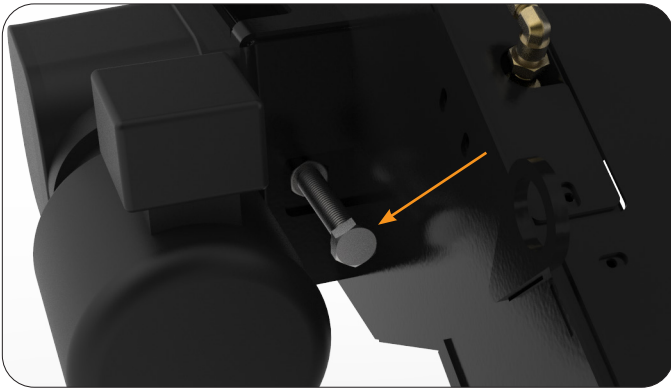

Fig. 4a

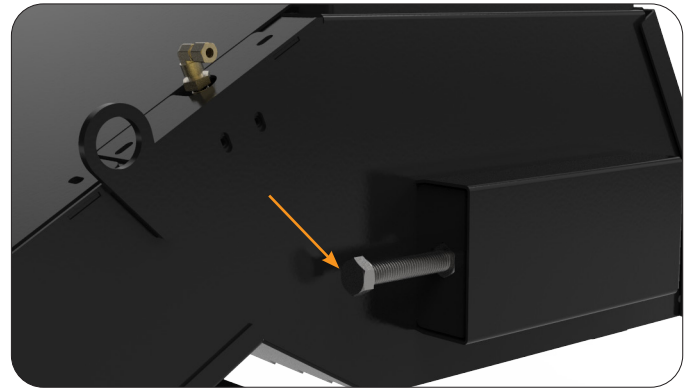

Fig. 4b

### 4.4 VISUALLY INSPECT BELT FOR DAMAGE

General inspection of the belt can be accomplished at the discharge opening at the head of the conveyor (by removal of the flip lid, or through openings in the trough).

#### What to look for when inspecting the belt:

- ① Ensure rollers are rotating freely and check for wear.
- ② Check belt shafts for wear.
- ③ Ensure the cleats are in good condition.
- ④ Check hinge plates for damage.

**To get a detailed inspection of the belt assembly, a complete removal of the belt from the conveyor body is recommended. This will provide complete access to all the integrated components.**

- ① Cleat    ② Hinge Plate    ③ Shaft    ④ Slip Fit link Connector    ⑤ Slip Fit Link    ⑥ Side Plate (wing)

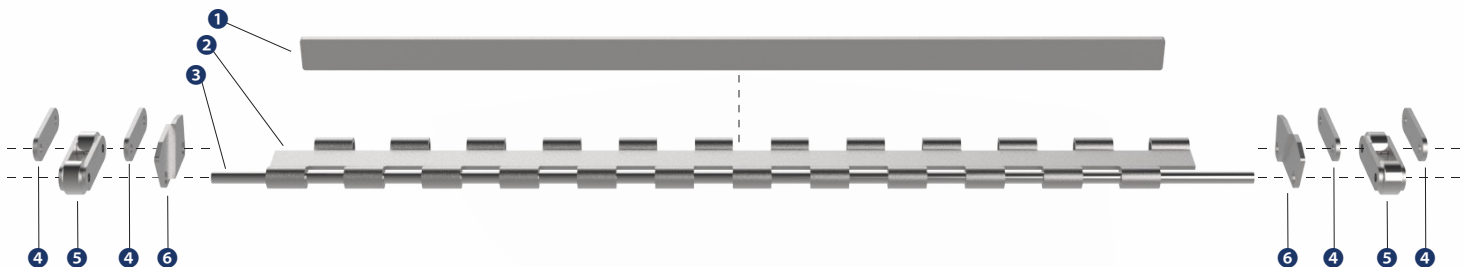

Fig. 4c



## 5. HINGE BELT REMOVAL

### 5.1 RAISE THE FLIP LID

Flip the “flip lid” up, exposing the drive shaft and hinge belt so they are visible at the top of the discharge chute.

---

### 5.2 LOCATE THE MASTER SHAFT

- ① Run the conveyor until the master shaft (identified as shaft with cotter pins and washers is visible at the top of the discharge chute.
- ② Turn off the system and disconnect the power cable.

**If the conveyor is jammed and the master shaft cannot be moved to the discharge end, any other shaft can be removed by grinding the crimp from the end of the shaft. If this is the case, do not perform this task until you’ve completed steps 5.3 and 5.4.**

---

### 5.3 REMOVE THE MOTOR

Remove the motor by removing the (4) fastener sets and pulling it off the drive shaft. This will allow the drive shaft to freewheel so the hinge belt may be easily removed.

---

### 5.4 LOOSEN THE JAM NUTS / TENSION SCREWS

Loosen the jam nuts and tension screws to remove pressure on the drive shaft. *See Fig 4a and 4b.*

---

### 5.5 REMOVE THE MASTER SHAFT

Remove the cotter pin from the master shaft and slide the shaft out of the belt assembly. This will disconnect the belt.

**If the belt is jammed and the master shaft cannot be accessed, grind the crimp off of the shaft closest to the discharge end and slide out the shaft.**

---

### 5.6 REMOVE THE BELT

**Re-install the master shaft into the top section of the belt only (trailing end) to ensure easy belt removal.**

Pull the hinge belt out lower side of the discharge chute (the master shaft should trail the belt assembly as it comes out).  
Having a pallet or bin to receive the belt helps with transporting it later.

## 6. HINGE BELT INSTALLATION

### 6.1 PREP THE HINGE BELT

Slide the master shaft into the leading edge of the belt. Position the belt so the side wing plates are facing down towards the bottom of the in-feed.

---

### 6.2 FEED HINGE BELT INTO THE SYSTEM

Feed the hinge belt down the lower rail system. Continue feeding the belt through until both ends meet back up at the discharge of the CDF conveyor.

---

### 6.3 CONNECT THE BELT ENDS

Remove the master shaft from the leading edge of the belt and mesh the two ends of the belt assembly together. Slide the master shaft through the mating parts of the belt assembly, and install washers and cotter pin on each side of the belt.

---

### 6.4 SET THE BELT TENSION

Set the final tension of the hinge belt by adjusting the tension screws on each side of the belt.

**Torque the tension screws to 25 in-lbs for proper belt tension.**

---

### 6.5 INSTALL THE MOTOR

Install the motor and key on the drive shaft.

---

### 6.6 LOWER THE FLIP LID

Lower the flip so you can safely proceed with powering up the system

---

### 6.7 POWER UP THE SYSTEM

Provide power to the motor by attaching power cables and connectors to the motor. Turn the system on.

---

### 6.8 RUN / MONITOR THE SYSTEM

Using the manual provided for the VFD/control box, run the belt forward and backward for a few minutes, completing 5 to 10 belt revolutions each way. Monitor the hinge belt to look for even, smooth movement.

# 7. SPARE PARTS

**Parts work for both A & B systems.** For detailed images of the individual parts, see pages 13-14. For belt parts, see page 14.

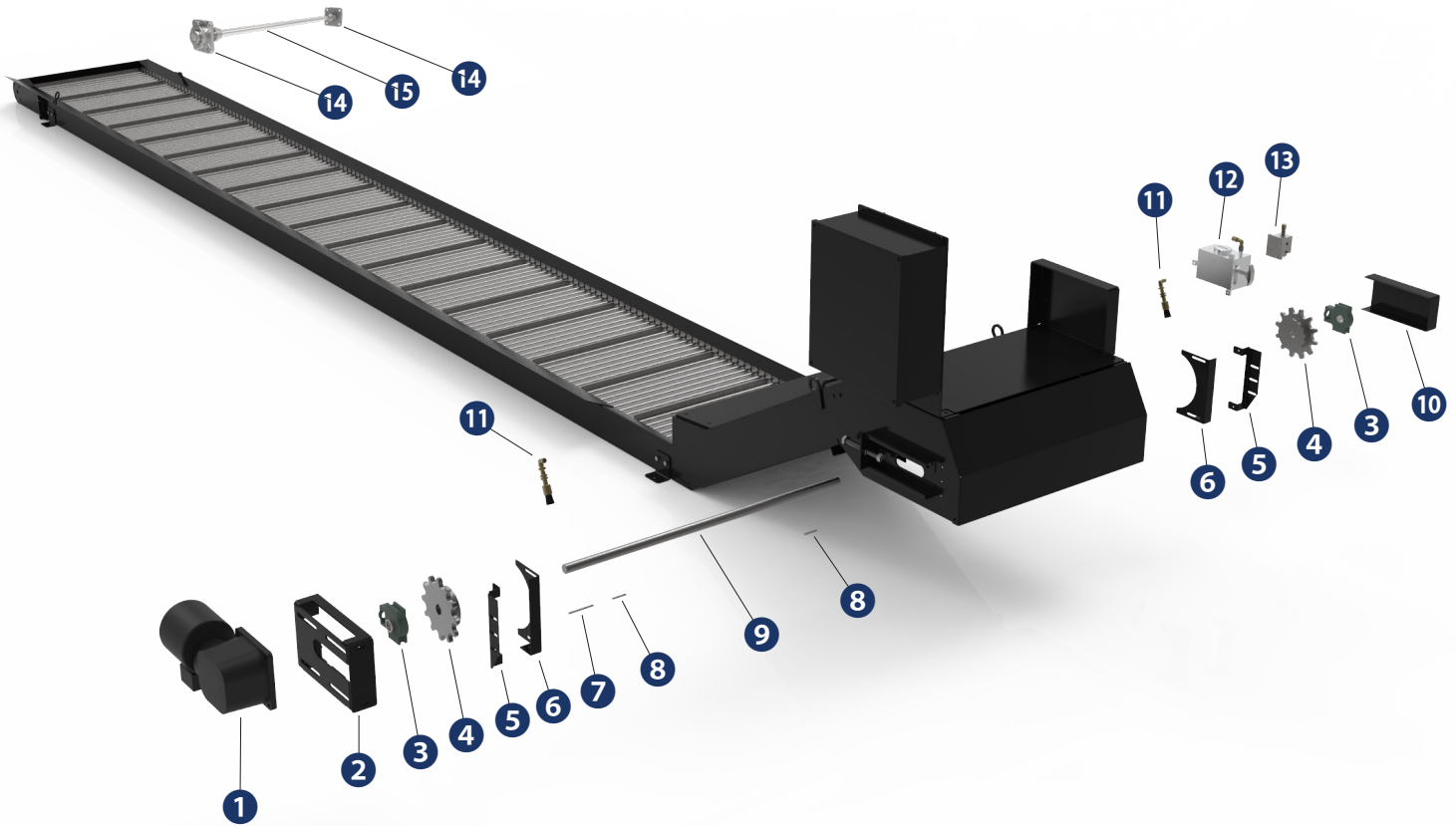













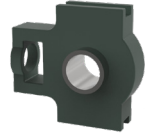

	PART NUMBER	DESCRIPTION	QUANTITY
1	MC1130-1	Gearmotor, 1/4 hp	1
2	123153-12S	Motor bracket	1
3	870010	Bearing, take up, 1.0" bore	2
4	873213	Drive sprocket, 2060b15, 1.0" bore	2
5	12315-17	Pinch guard (l & r parts)	2
6	12315-17A	Pinch guard cover (l & r parts)	2
7	892030-5KS	Drive motor key	1
8	892030-5K	Belt sprocket key	2
9	892030-8	Drive shaft	1
10	12315-7	Take up bearing cover	1
11	M2897	Oiler brush assembly, vlv, elbow, brush	2
12	885392	Manual oil pump	1
13	885388	Lubrication manifold	1
14	870003	*Flange bearing, 4-hole, 3/4" id (idler)	2
15	M2879	Idler assembly (includes flange bearing)	1
16	896015-8-R-D	Hinge kit, dimpled hinge	as needed
17	896015-8-R-CLEAT	Hinge kit, cleated	as needed
18	896015-8-308-R-D	Replacement hinge belt (dimpled)	1

Quantities are per conveyor

\* Flange bearing sold individually or as a unit with the idler assembly (15)

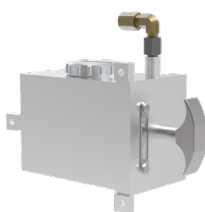
# 7. SPARE PARTS

## DRIVE & FRAME PARTS *(Quantities are per conveyor)*

 <p><b>1</b> <b>MC1130-1</b> Gear motor 1/4 hp Qty 1</p>	 <p><b>2</b> <b>123153-12S</b> Motor bracket Qty 1</p>	 <p><b>3</b> <b>870010</b> Bearing, Take up 1.0" bore Qty 2</p>	 <p><b>4</b> <b>873213</b> Drive sprocket 1.0" bore, 2060b15 Qty 2</p>	 <p><b>5</b> <b>12315-17</b> Pinch guard Qty 2</p>
 <p><b>6</b> <b>12315-17A</b> Pinch guard cover Qty 2</p>	 <p><b>7</b> <b>892030-5KS</b> Drive motor key Qty 1</p>	 <p><b>8</b> <b>892030-5K</b> Belt sprocket keys Qty 2</p>	 <p><b>9</b> <b>892030-8</b> Drive shaft Qty 1</p>	
 <p><b>10</b> <b>12315-7</b> Take Up bearing cover Qty 1</p>	 <p><b>11</b> <b>M2897</b> Oiler brush assembly vlv, elbow, brush Qty 2</p>	 <p><b>12</b> <b>885392</b> Manual oil pump Qty 1</p>	 <p><b>13</b> <b>885388</b> Lubrication manifold Qty 1</p>	
 <p><b>14</b> <b>870003</b> *Flange bearing (idler) 4-hole, 3/4" id Qty 2</p>	 <p><b>15</b> <b>M2879</b> Idler assembly (includes flange bearing) Qty 1</p>		<p>* Flange bearing sold individually or as a unit with the idler assembly (15)</p>	

## 7. SPARE PARTS

### REPLACEMENT BELTS & BELT KITS



**16** 896015-8-R-D  
\*Hinge kit  
(dimpled hinge)



**17** 896015-8-R-CLEAT  
\*Hinge Kit (cleated)

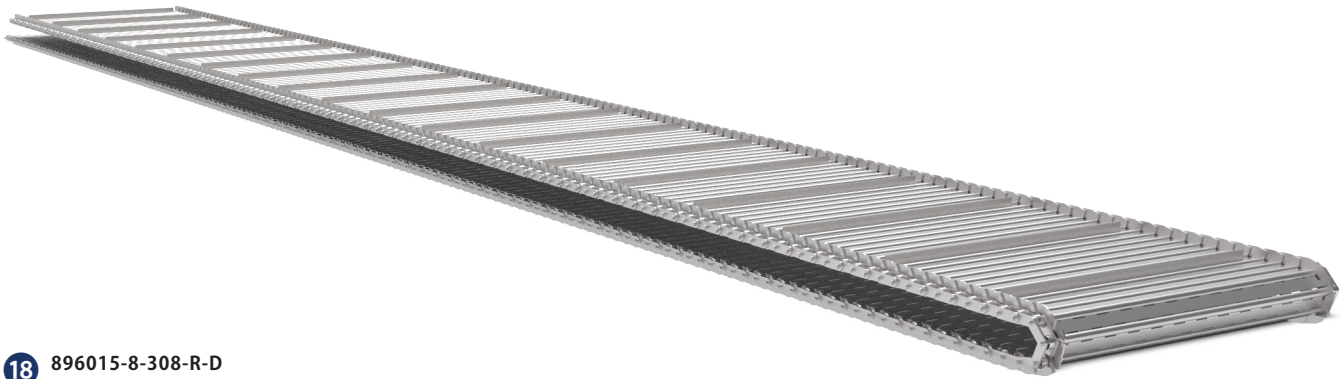

**18** 896015-8-308-R-D  
Replacement hinge  
belt (dimpled)

### ORDER SPARE PARTS

[www.hennigworldwide.com/spare-parts](http://www.hennigworldwide.com/spare-parts)

815-636-9900

[info@hennig-inc.com](mailto:info@hennig-inc.com)



**PROTECT** YOUR SUCCESS

For over 65 years, Hennig has been defining excellence in machine protection, creating regional jobs, serving their local communities, and supporting the global needs of machine tool customers.

### **MACHINE PROTECTION**

Telescopic Steel Covers  
XY Face Shields  
Bellows  
Aprons & Roll Up Covers  
Walk-On Covers  
Wiper Systems  
Telescopic Springs  
Cable Carriers

### **CHIP SOLUTIONS**

Chip Conveyors  
Turnkey Chip Management  
Conveyor Networks  
Chip Disc Filtration (CDF)  
Coolant Filtration  
Coolant Tanks

### **ENCLOSURES & FACILITY SAFETY**

Walk-On Pit Covers  
Scissor Lift Bellows  
Machine Roof Bellow Covers  
Double Column Enclosures  
GENSET Enclosures

Data Subject To Change    102315-0223    Printed in the USA    Copyright 2023



[hennigworldwide.com](http://hennigworldwide.com)